

Ø 20mm Brushless

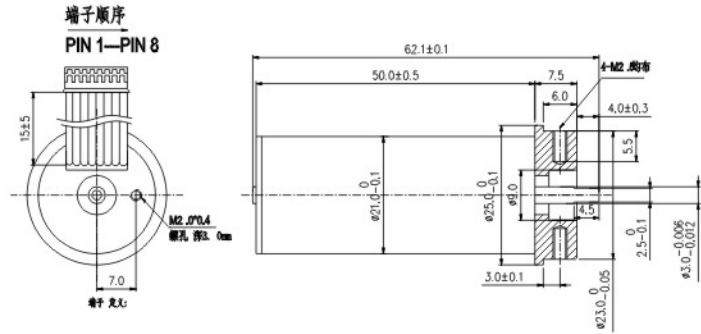

CB2050	UNIT	001	002	003	004
RATED VOLTAGE(额定电压)	V/DC	30			
RATED SPEED(额定转速)	RPM	13050			
NO LOAD SPEED(空载转速)	RPM	15000			
NO LOAD CURRENT(空载电流)	mA	200			
RATED CURRENT(额定电流)	mA	1100			
RATED TORQUE(额定转矩)	mN.m	15			
RATED POWER(额定功率)	W	20.5			
MAX EFFICIENCY(最大效率)	%	70			
RESISTANCE PHASE TO PHASE	OHM	4.9			
TORQUE CONSTANT(转矩常数)	mN.m/A	18			
SPEED CONSTANT(速度常数)	rpm/V	500			
WEIGHT(重量)	g	80			

SPECIFICATION	
AMBIENT TEMPERATURE RANGE	-20 ~ 55°C
MAX PERMISSIBLE WINDING TEMPERATURE	85°C
MAX PERMISSIBLE SPEED	30000rpm
MAX AXIAL LOAD	2.0N
MAX RADIAL LOADING	8.0N
NUMBER OF THE POLE PAIR	1
NUMBER OF THE PHASES	3

Application

Electric Screw Driver(电钻)etc

