

60W
□90mm

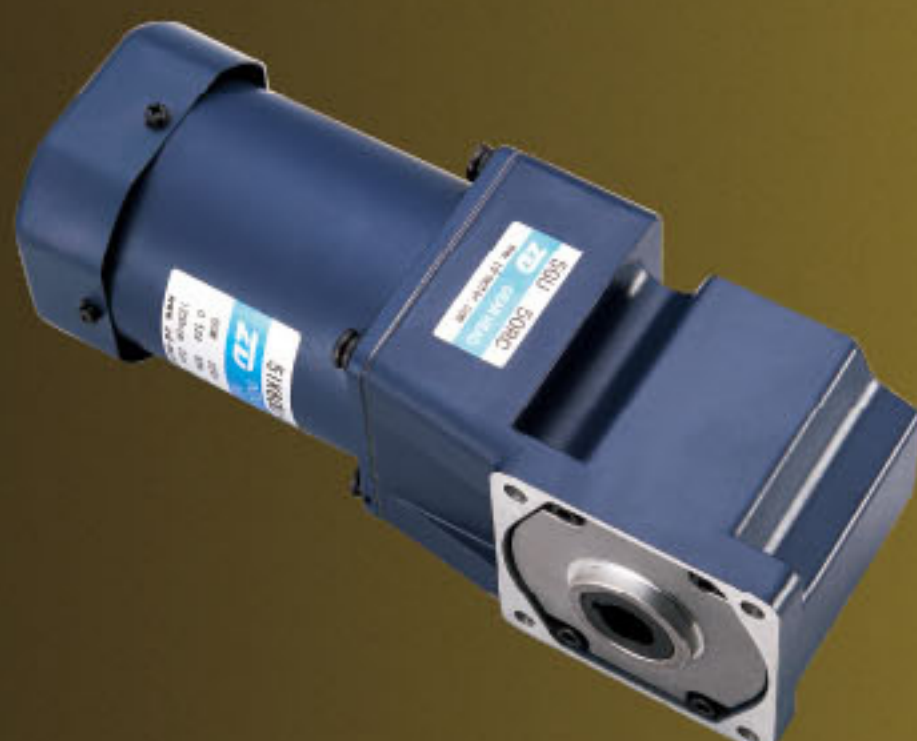

■ 装有减速器时的容许转矩 GEAR MOTOR-TORQUE TABLE

- 减速器·中间减速器另售。• 电动机型号的□中为表示带端子箱型的记号(T)
- 减速器型号的□中为减速比的数值。• □色表示与电动机同一方向运转，其他则为相反方向。
- 转速是以电动机的同步转速(50Hz: 1500r/min、60Hz: 1800r/min)为基准除以减速比而算出来的数值。实际转速将随负载大小变化而比所示数值减少2%~20%左右。
- 希望以大于下表的减速比进行进一步减速时，可在电动机与减速器之间安装减速比为10的中间减速器。这时的容许转矩为20N·m。
- Gearhead and mid-gearbox can be sold separately.
- Enter the code that represents the terminal box type (T) in the box (□) within the model name. • Enter the gear ratio in the box (□) within the model name.
- The colored background □ indicates the same rotating direction of the motor while the rotating direction of others are opposite.
- The speed is calculated by dividing the motor's synchronous speed (50Hz: 1500r/min、60Hz: 1800r/min) by the gear ratio. The actual speed is 2%~20% less than the displayed value, depending on the size of the load.
- To reduce the speed beyond the gear ratio in the table, attach a mid-gearbox (gear ratio: 10) between the gearhead and motor. In that case, the permissible torque is 20N·m.

容许力矩单位 Allowance Torque Unit: 上段 Upside (N·m) / 下段 Belowside (kgf·cm)

机型Type 电动机/减速器 Motor/Gearhead	减速比Gear Ratio	容许力矩 Allowance Torque																				
		3	3.6	5	6	7.5	9	12.5	15	18	25	30	3.6	50	60	75	90	100	120	150	180	
5IK60GU-A□F 5IK60GU-E□F 5IK60GU-C□F 5IK60GU-H□F 5IK60GU-S□F	5GU□RC 5GU□RT	50Hz	500	417	300	250	200	166	120	100	83	60	50	417	30	25	20	16	15	12	10	8
		60Hz	600	500	360	300	240	200	144	120	100	72	60	500	36	30	24	20	18	15	12	10
5IK60GU-A□F 5IK60GU-E□F 5IK60GU-C□F 5IK60GU-H□F 5IK60GU-S□F	5GU□RC 5GU□RT	50Hz	0.85	1.02	1.42	1.70	2.37	2.84	3.95	4.73	5.68	7.89	9.47	10.2	14.2	17.0	20.0	20.0	20.0	20.0	20.0	20.0
		60Hz	0.69	0.82	1.15	1.37	1.91	2.29	3.18	3.82	4.58	6.36	7.64	8.25	11.5	13.7	17.2	20.0	20.0	20.0	20.0	20.0
5IK60GU-A□F 5IK60GU-E□F 5IK60GU-C□F 5IK60GU-H□F 5IK60GU-S□F	5GU□RC 5GU□RT	60Hz	6.73	8.08	11.2	13.5	19.48	23.37	32.46	38.96	46.75	64.93	77.92	84.1	117	140	175	200	200	200	200	200

感应、可逆尺寸图 INDUCTION, REVERSIBLE TYPE DRAWING

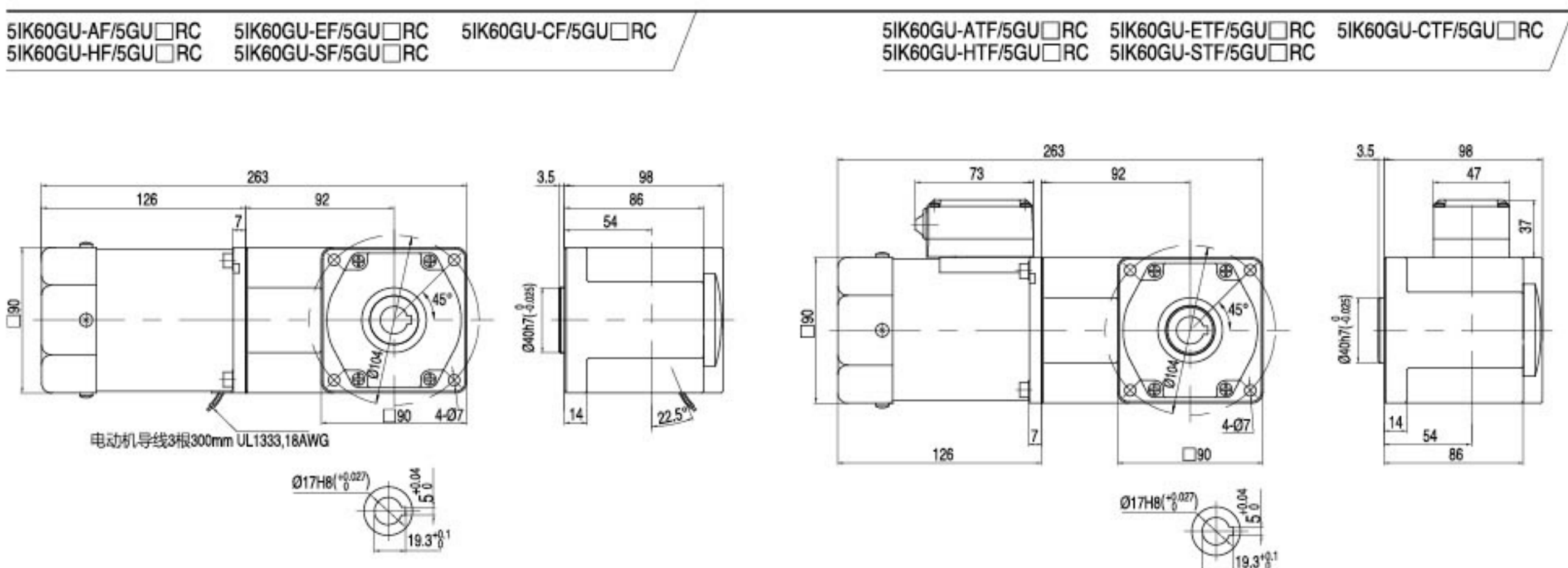

感应、可逆尺寸图 INDUCTION, REVERSIBLE TYPE DRAWING

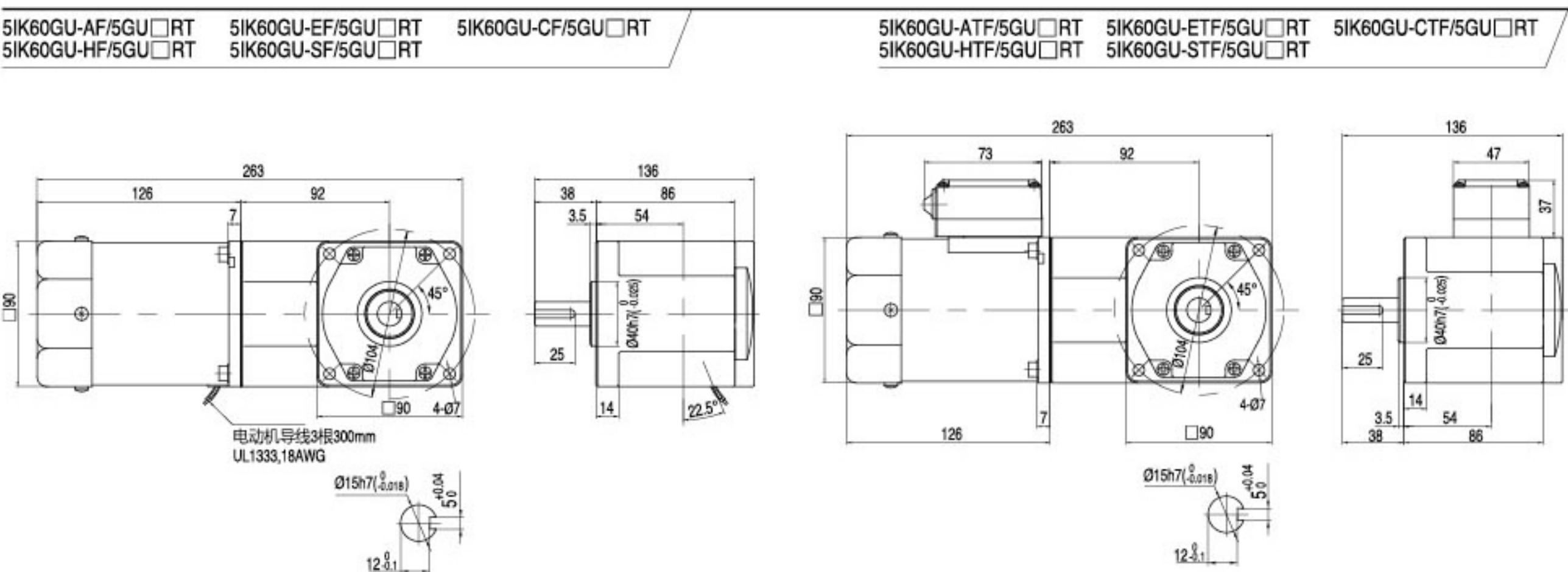

调速尺寸图 SPEED CONTROL TYPE DRAWING

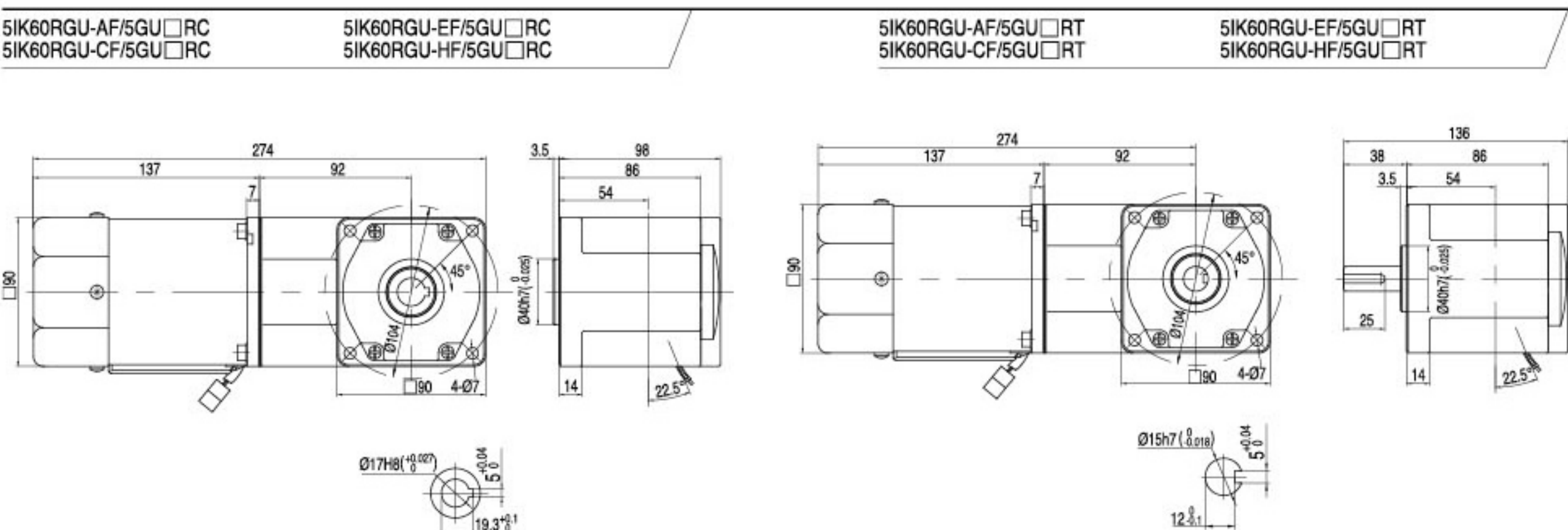

注: 接插件配中大标准型调速器 Note: The connector is for ZD standard speed controller.

刹车尺寸图 BRAKE TYPE DRAWING

