

140W  
□104mm



**装有减速器时的容许转矩 GEAR MOTOR-TORQUE TABLE**

- 电动机型号的□中为表示带端子箱型的记号 (T)
- 减速器型号的□中为减速比的数值。
- 色表示与电动机同一方向运转，其他则为相反方向。
- 转速是以电动机的同步转速 (50Hz: 1500r/min、60Hz: 1800r/min) 为基准除以减速比而算出来的数值。实际转速将随负载大小变化而比所示数值减少2%~20%左右。
- 减速器容许转矩为60N·m。
- Enter the code that represents the terminal box type (T) in the box (□) within the model name. • Enter the gear ratio in the box (□) within the model name.
- The colored background □ indicates the same rotating direction of the motor while the rotating direction of others are opposite.
- The speed is calculated by dividing the motor's synchronous speed (50Hz: 1500r/min、60Hz: 1800r/min) by the gear ratio. The actual speed is 2%~20% less than the displayed value, depending on the size of the load.
- the permissible torque is 60N·m.

**容许力矩单位 Allowance Torque Unit: 上段 Upside (N.m) /下段 Belowside (kgf.cm)**

机型Type 电动机/减速器 Motor/Gearhead	减速比Gear Ratio	容许力矩 Allowance Torque																				
		3	3.6	5	6	7.5	9	12.5	15	18	25	30	3.6	50	60	75	90	100	120	150	180	
6IK140GU-A□F 6IK140GU-E□F 6IK140GU-C□F 6IK140GU-H□F 6IK140GU-S□F	6GU□RC 6GU□RT	50Hz	1.99	2.39	3.31	3.98	4.97	6.63	9.21	11.0	13.3	18.4	22.1	26.5	33.1	39.8	49.7	59.6	60.0	60.0	60.0	60.0
		60Hz	20.3	24.3	33.8	40.6	50.7	67.6	93.9	113	135	188	225	271	338	406	507	600	600	600	600	600
		50Hz	1.60	1.92	2.67	3.21	4.01	5.34	7.42	8.91	10.7	14.8	17.8	21.4	26.7	32.1	40.1	48.1	53.4	60.0	60.0	60.0
		60Hz	16.4	19.6	27.3	32.7	40.9	54.5	75.8	90.9	109	152	182	218	273	327	409	491	545	600	600	600

**感应尺寸图 INDUCTION TYPE DRAWING**

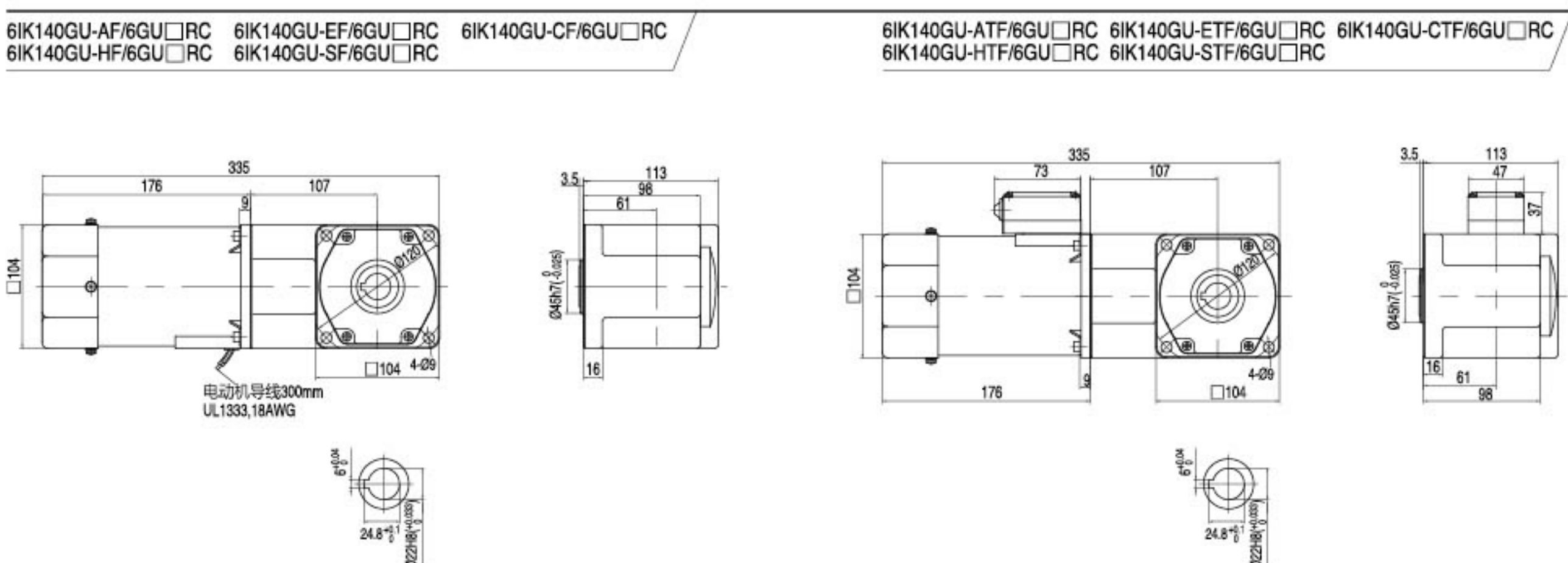

**感应尺寸图 INDUCTION TYPE DRAWING**

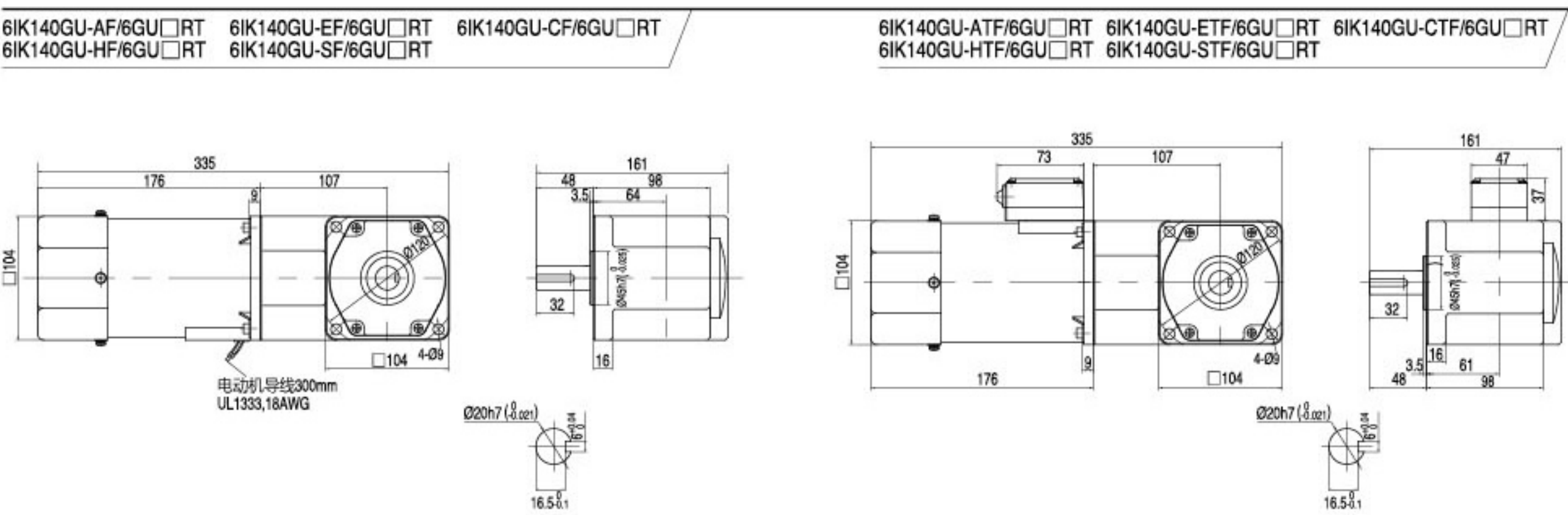

**调速尺寸图 SPEED CONTROL TYPE DRAWING**

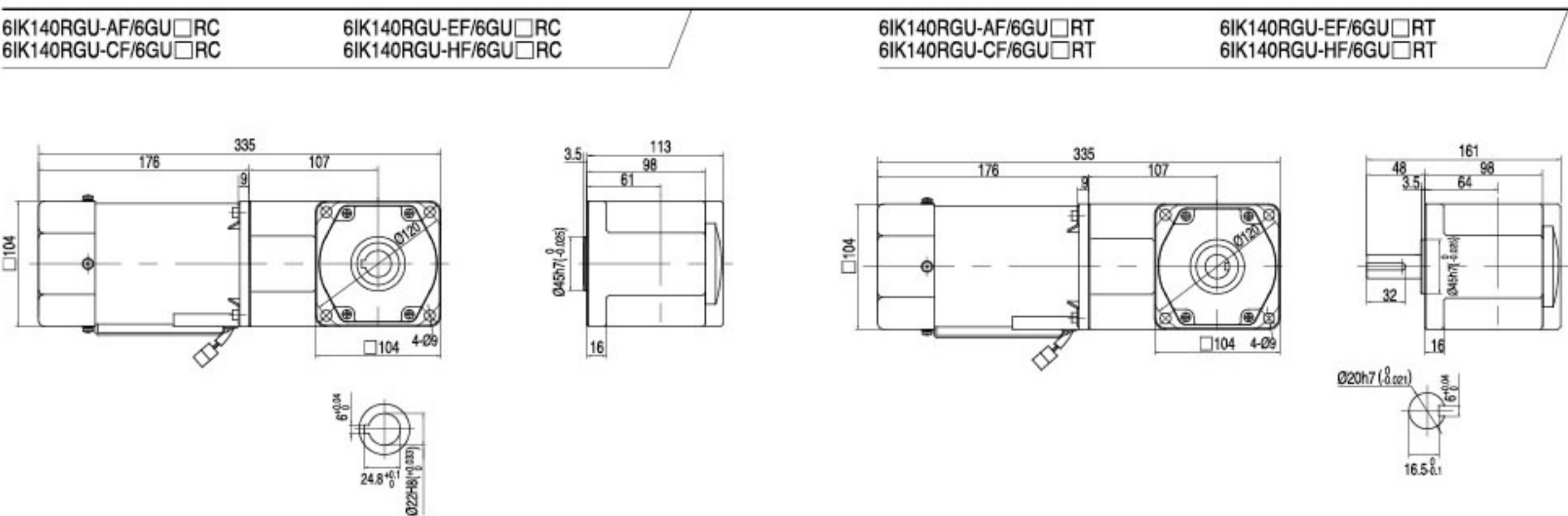

注: 接插件配中大标准型调速器 Note: The connector is for ZD standard speed controller.

**刹车尺寸图 BRAKE TYPE DRAWING**

