

调速电动机 Speed Control Motors

25W

□80mm



规格Specs 连续额定Cont. Rated

型号Model · 类型Type 导线型Wire Type		最大 输出功率 Output Power W	电压 Voltage V	频率 Frequency Hz	调速范围 Speed Control Range r/min	容许转矩 Allowance Torque		启动转矩 Starting Torque mN.m	电流 Current A	电容器容量 Capacitor μF
齿轮轴型 Pinion Shaft	圆轴型 Round Shaft					1200r/min mN.m	90r/min mN.m			
4IK25RGN-AJ	4IK25RA-AJ	25	1ph100	50	90~1400	190	47	88	0.75	8.0
				60	90~1700					
4IK25RGN-EJ	4IK25RA-EJ	25	1ph110	60	90~1700	190	50	105	0.75	7.0
			1ph120							
4IK25RGN-CE	4IK25RA-CE	25	1ph220	50	90~1400	190	47	88	0.35	1.5
			1ph230							
4IK25RGN-HE	4IK25RA-HE	25	1ph220	60	90~1700	130	45	88	0.33	
			1ph230							

- 电动机铭牌上的型号并无表示电容器种类的(J、E)记号。
With the name on record on the motor nameplate, there is no capacitor types(J、E) marked.
- 各种安全规格以电动机铭牌上的型号取得认证。
When the motor is approved under various safety standards, the model name on the nameplate is the approved model name.

种类/Type

电动机/Motor

机型 Type	型号Model	
	齿轮轴型 Pinion Shaft	圆轴型 Round Shaft
导线型 Lead Wire Type	4IK25RGN-AJ	4IK25RA-AJ
	4IK25RGN-EJ	4IK25RA-EJ
	4IK25RGN-CE	4IK25RA-CE
	4IK25RGN-HE	4IK25RA-HE

平行轴减速器(另售)/
Parallel Shaft Gearhead (Sold Separately)

减速器种类 Gearhead Type	减速器型号 Gearhead Model	减速比Gear Ratio
长寿命·低噪音 Long Life · Low Noise	4GN□K	3、3.6、5、6、7.5、9、 12.5、15、18、25、30、 36、50、60、75、90、 100、120、150、180、200
	4GN10XK (中间减速器Decimal gearhead)	

- 减速器型号的□中为减速比的数值
Enter the gear ratio in the box (□) within the model name

◇ 键 · 键槽(减速器附件)Key · Key Slot
(The key is included with the gearhead)

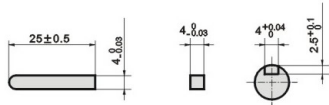

◇ 圆轴型的转轴部分 Shaft Section of Round Shaft Type

除重量及轴部外,电动机外形与齿轮轴型相同。
Excluding weight and the shaft section
Motor shape are the same as those of the pinion shaft

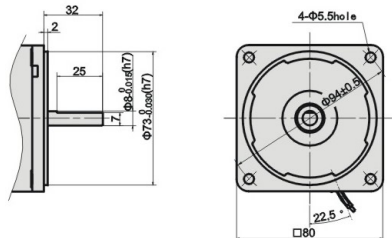

◇ 中间减速器 Decimal Gearhead

可安装在GN齿轮轴型上。
Can be connected to GN pinion shaft type
4GN10XK
重量weight: 0.41kg

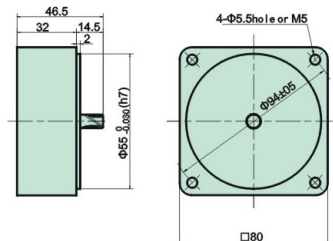

◇ 连接图 Connection Diagrams

US型/US Type

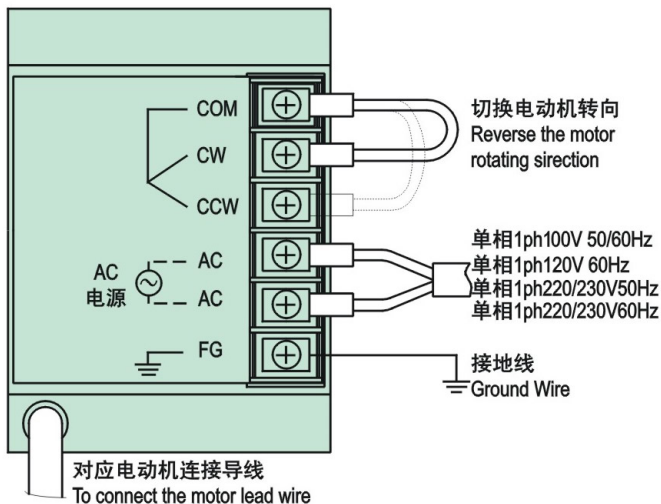

SS型/SS Type

