

可逆电动机 REVERSIBLE MOTORS

25W

□80mm

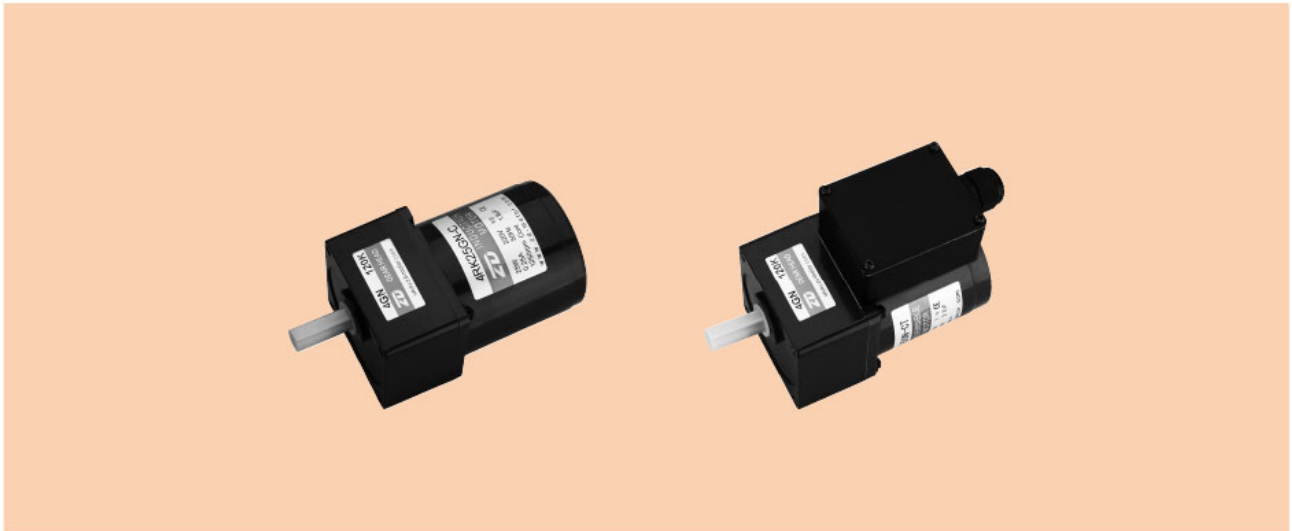

规格 / 30分钟额定 SPECS / 30MINUTES RATING

型号 Model 类型 Type	输出功率 Output power W	电压 Voltage V	频率 Frequency Hz	电流 Current A	启动转矩 Starting Torque mN.m	额定转矩 Rated Torque mN.m	额定转速 Rated Speed r/min	电容器容量 Capacitor μ F
上段: 齿轮轴 Above: gearbox 下段 () 内: 圆轴 below in (): round shaft								
导线型 Lead Wire Type 外形图 Drawing ①	带端子箱型 Terminal Box Type 外形图 Drawing ②							
4RK25GN-A (4RK25A-A)	4RK25GN-AT (4RK25A-AT)	25	1ph100	50	0.59	160	1250	10
4RK25GN-E (4RK25A-E)	4RK25GN-ET (4RK25A-ET)	25	1ph110 1ph120	60	0.45 0.50	140	1550	8.0
4RK25GN-C (4RK25A-C)	4RK25GN-CT (4RK25A-CT)	25	1ph220 1ph230	50	0.29 0.30	140	1250	2.2
4RK25GN-H (4RK25A-H)	4RK25GN-HT (4RK25A-HT)	25	1ph220 1ph230	60	0.35	140	1550	

●可逆电动机的额定转矩、启动转矩数值均为未安装简易制动时的数值。●各种安全规格以电动机铭牌上的型号取得认定。●Ⓜ:内藏热保护装置(自动复位型)。在电机因某种原因过热时会自行启动使电动机停止。●电动机温度下降后恢复运行,故在进行检查作业时请务必事先切断电源。

●Values shown for rated torque and starting torque are measured for operation without the friction brake installed. ●When the motor is approved under various safety standards, the model name on the nameplate is the approved model name. ●Contains a built-in thermal protector (automatic return). If a motor overheats for any reason, the thermal protector is opened and the motor stops. ●When the motor temperature drops, the thermal protector closes and the motor restarts. Be sure to turn the motor off before inspecting.

种类 TYPE

●电动机 MOTOR

机型 Type	型号 Model	
	齿轮轴型 Pinion Shaft	圆轴型 Round Shaft
导线型 Lead Wire Type	4RK25GN-A	4RK25A-A
	4RK25GN-E	4RK25A-E
	4RK25GN-C	4RK25A-C
	4RK25GN-H	4RK25A-H
带端子箱型 Terminal Box Type	4RK25GN-AT	4RK25A-AT
	4RK25GN-ET	4RK25A-ET
	4RK25GN-CT	4RK25A-CT
	4RK25GN-HT	4RK25A-HT

●平行轴减速器(另售) PARALLEL SHAFT GEARHEAD (SOLD SEPARATELY)

减速器种类 Gearhead Type	减速器型号 Gearhead Model	减速比 Gear Ratio
长寿命·低噪音 Long Life · Low Noise	4GN□K	3、3.6、5、6、7.5、9、12.5、15、18、25、30、36、50、60、75、90、100、120、150、180、200
	4GN10XK (中间减速器 Mid-gearbox)	

- 减速器型号的□中为减速比的数值
- Enter the gear ratio in the box (□) within the model name

■ 装有减速器时的容许转矩

ALLOWABLE TORQUE WHEN BEING WITH REDUCER

- 减速器·中间减速器另售
- 电动机型号的□中为表示带端子箱型的记号(T)
- 减速器型号的□中为减速比的数值。
- □色表示与电动机同一方向运转，其他则为相反方向。
- 转速是以电动机的同步转速(50Hz: 1500r/min、60Hz: 1800r/min)为基准除以减速比而算出来的数值。实际转速将随负载大小变化而比所示数值减少2%~20%左右。
- 希望以大于下表的减速比进行进一步减速时，可在电动机与减速器之间安装减速比为10的中间减速器。这时的容许转矩为8N·m。但安装了1/25~1/36的减速器时，容许转矩为8N·m。
- Gearhead and mid-gearbox can be sold separately.
- Enter the code that represents the terminal box type (T) in the box (□) within the model name.
- Enter the gear ratio in the box (□) within the model name.
- The colored background □ indicates the same rotating direction of the motor while the rotating direction of others are opposite.
- The speed is calculated by dividing the motor's synchronous speed (50Hz: 1500r/min、60Hz: 1800r/min) by the gear ratio. The actual speed is 2%~20% less than the displayed value, depending on the size of the load.
- To reduce the speed beyond the gear ratio in the table, attach a mid-gearbox (gear ratio: 10) between the gearhead and motor. In that case, the permissible torque is 8 N·m. When a gearhead of 1/25~1/36 is connected, the value for permissible torque is 8N·m.

容许力矩单位 Allowance Torque Unit: 上段 Upside (N.m) / 下段 Belowside (kgf.cm)

机型Type	减速比Gear Ratio	3	3.6	5	6	7.5	9	12.5	15	18	25	30	36	50	60	75	90	100	120	150	180	200		
电动机/减速器 Motor/Gearhead	转速Speed r/min	50Hz	500	417	300	250	200	166	120	100	83	60	50	41	30	25	20	16	15	12.5	10	8.3	7.5	
	60Hz	600	500	360	300	240	200	144	120	100	72	60	50	36	30	24	20	18	15	12	10	9		
4RK25GN-A-□ 4RK25GN-E-□ 4RK25GN-C-□ 4RK25GN-H-□	4GN□K	50Hz	0.49	0.58	0.81	0.97	1.2	1.5	2.0	2.4	2.9	3.7	4.4	5.3	6.6	7.9	8	8	8	8	8	8	8	
			5.00	5.91	8.26	9.89	12.2	15.3	20.4	24.4	29.6	37.7	44.9	54.1	67.3	80	80	80	80	80	80	80	80	
		60Hz	0.40	0.48	0.67	0.80	1.0	1.2	1.7	2.0	2.4	3.0	3.6	4.3	5.4	6.5	8	8	8	8	8	8	8	8
			4.08	4.89	6.83	8.16	10.2	12.2	17.3	20.4	24.4	30.6	36.7	43.8	55.1	66.3	80	80	80	80	80	80	80	80

■ 容许悬挂负载·容许轴向负载

PERMISSIBLE OVERHUNG LOAD AND THRUST LOAD

电动机(圆轴型)→217页

Motor (Round Shaft)→P217

减速器→217页

Gearhead→P217

■ 减速器的容许负载惯性惯量J

PERMISSIBLE LOAD INERTIA J FOR GEARHEAD

→218页→P218

■ 外形图(单位 mm)

DIMENSIONS(Unit mm)

减速器附有安装用螺丝

Mounting screws are included with gearhead.

● 导线型 Lead wiring Type ①

重量 Weight: 电动机 Motor 1.6kg 减速器 Gearhead 0.80kg

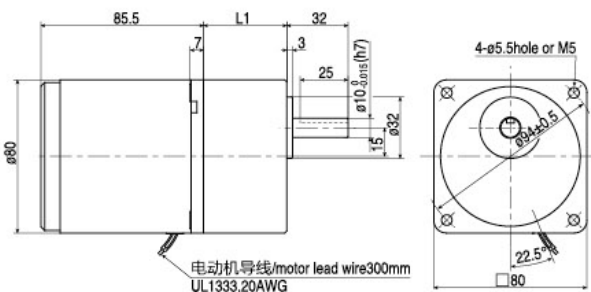

电动机型号 Motor Model	减速器型号 Gearhead Model	减速比 Gear Ratio	L1
4RK25GN-A	4GN□K	3~18	32
4RK25GN-E		25~200	43.5
4RK25GN-C			
4RK25GN-H			

- 减速器型号的□中为减速比的数值
- Enter the gear ratio in the box (□) within the model name

带端子箱型 Terminal Box Typ ②

重量 Weight: 电动机 Motor 1.80kg 减速度 Gearhead 0.80kg

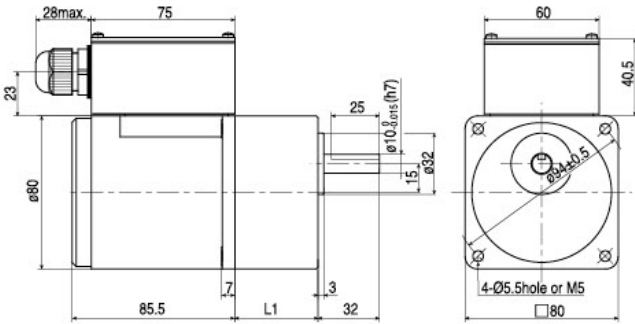

●适用电缆直径为 Use canle with a diameter of $\phi 6\sim\phi 12\text{mm}$

键·键槽 (减速度附件) Key-keyway (The key is included with the gearhead)

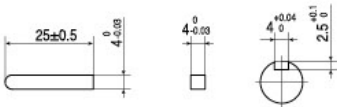

圆轴型的转轴部分 Shaft Section of Round Shaft Type

除重量及轴部外, 电动机外形与齿轮轴相同
Excluding weight and the shaft section Motor shape are the same as those of the pinion shaft type

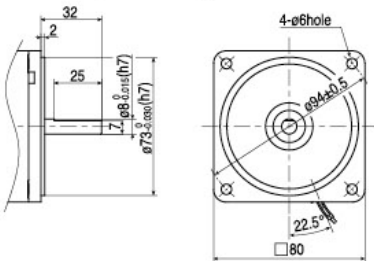

电动机型号 Motor Model	减速度型号 Gearhead Model	减速度 Gear Ratio	L1
4RK25GN-AT	4GN□K	3~18	32
4RK25GN-ET			
4RK25GN-CT		25~200	43.5
4RK25GN-HT			

- 减速度型号的□中为减速比的数值
- Enter the gear ratio in the box (□) within the model name

中间减速度 Mid-gearbox

可安装在GN齿轮轴型上
Can be connected to GN pinion Shaft type 4GN10XK
重量 Weight: 0.6kg

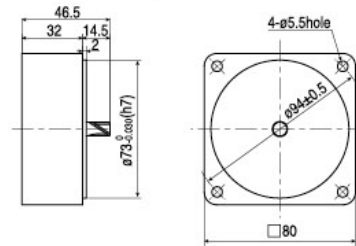

电容器外形尺寸 Formal Dimension of Capacitor

型号 Model		电容器型号 Capacitor Model	L	W	H
齿轮轴型 Pinion Shaft	圆轴型 Round Shaft				
4RK25GN-A□	4RK25A-A□	ZD100CFAUL	38	19	29
4RK25GN-E□	4RK25A-E□	ZD80CFAUL	38	17	28
4RK25GN-C□	4RK25A-C□	ZD22BFAUL	38	15	27

- 常规电容器出线为引线, 也可根据客户要求配置插片式187#
- 电动机型号的□中为表示带端子箱型的记号 (T)
- Note: Conventional capacitor is a lead wire type. Inserted 187# is optional
- Enter the code that represents the terminal box type (T) in the box (□) within the model name

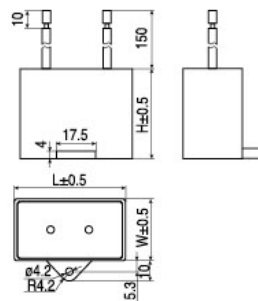

连接图 CONNECTION DIAGRAMS

- 运转方向指从电动机轴看来的方向。CW表示顺时针方向，CCW表示逆时针方向。
- 表中所记型号为齿轮轴型，圆轴型亦同。
- The direction of motor rotation is as viewed from the shaft end of motor.
CW represents the clockwise direction, while CCW represents the counterclockwise direction.
- Name indicated in the list is pinion shaft type, also valid for the equivalent round.

导线型 Lead Wire Type		带端子箱型 Terminal Box Type	
4RK25GN-A、4RK25GN-E 4RK25GN-C、4RK25GN-H		4RK25GN-AT、4RK25GN-ET 4RK25GN-CT、4RK25GN-HT	
顺时针方向 CW	逆时针方向 CCW	顺时针方向 CW	逆时针方向 CCW

● 请注意 Note:

- 单相电动机运转方向的转换应在电动机停止后进行。
- 若在电动机运转时转换运转方向，可能发生无法转换运转方向或须费时较久的情况。
- Change the direction of single-phase motor rotation only after bring the motor to a stop.
- If an attempt is made to change the direction of rotation while the motor is rotating, motor may ignore reversing command or change its direction of rotation after some delay.