

6#齿轮箱出轴直径 ϕ 50mm配三相电机技术参数
6# GEARBOX WITH SHAFT DIA ϕ 50mm WITH 3-PHASE MOTOR PARAMETERS

6#齿轮箱出轴直径 ϕ 50mm配三相电机技术参数
6# GEARBOX WITH SHAFT DIA ϕ 50mm WITH 3-PHASE MOTOR PARAMETERS

卧式 HORIZONTAL 立式 VERTICAL

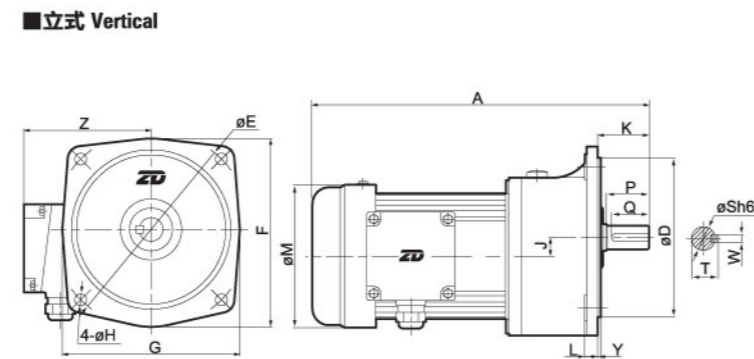
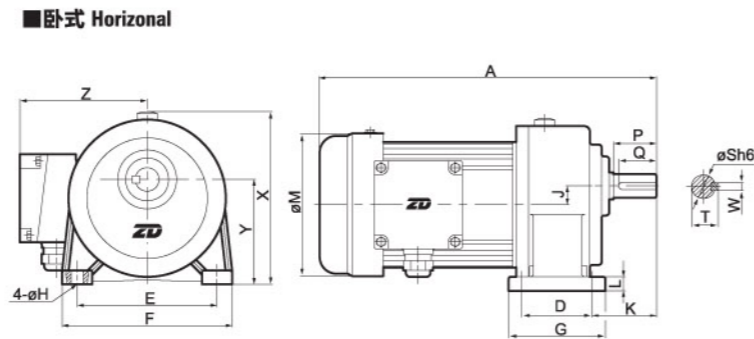

■尺寸表 Size Table

单位Unit: mm

功率Power	减速比Ratio	A	D	E	F	G	H	J	K	L	M	X	Y	Z	S	P	Q	W	T	重量Weight
750W 1HP	标准型250~1800 (3#+6#)	620	170 (280)	265 (390)	335 (369)	238 (341)	18	74	120 (92)	31.5 (25)	168	308 (/)	200 (5)	135	50	80	75	14	54	90
	/	/	/	/	/	/	/	/	/	/	/	/	/	/	/	/	/	/	/	/
1500W 2HP	标准型110~180	560	170 (280)	265 (390)	335 (369)	238 (335)	18	51	120 (92)	31.5 (25)	192	308 (/)	200 (5)	146	50	80	75	14	54	94
	/	/	/	/	/	/	/	/	/	/	/	/	/	/	/	/	/	/	/	/
2200W 3HP	标准型45~100	580	170 (280)	265 (390)	335 (369)	238 (335)	18	51	120 (92)	31.5 (25)	220	308 (/)	200 (5)	160	50	80	75	14	54	97
	/	/	/	/	/	/	/	/	/	/	/	/	/	/	/	/	/	/	/	/
3700W 5HP	标准型15~60	620	170 (280)	265 (390)	335 (369)	238 (335)	18	51	120 (92)	31.5 (25)	220	308 (/)	200 (5)	160	50	80	75	14	54	98
	/	/	/	/	/	/	/	/	/	/	/	/	/	/	/	/	/	/	/	/

※表中()内为立式电机尺寸。
 ※labulation "(/)" denote Vertical motor dimension.

■输出轴容许扭矩Output Torque

单位Unit: kg-m

功率Power	类型Type	频率Frequency	速比Ratio	扭矩Torque																					
				3	5	10	15	20	25	30	40	45	50	60	70	80	90	100	120	140	160	180	200		
1500W 2HP	标准型 Standard type	50Hz	/	/	/	/	/	/	/	/	/	/	/	/	/	/	/	/	/	101	116	132	148	/	
		60Hz	/	/	/	/	/	/	/	/	/	/	/	/	/	/	/	/	/	83.7	96.8	110	123	/	
	缩框型 Light duty type	50Hz	/	/	/	/	/	/	/	/	/	/	/	/	/	/	/	/	/	/	/	/	/	/	/
		60Hz	/	/	/	/	/	/	/	/	/	/	/	/	/	/	/	/	/	/	/	/	/	/	/
2200W 3HP	标准型 Standard type	50Hz	/	/	/	/	/	/	/	59.8	65.1	78.1	92.5	105	113	126	/	/	/	/	/	/	/	/	
		60Hz	/	/	/	/	/	/	/	49.6	54.3	65.1	77.1	87.5	94.3	105	/	/	/	/	/	/	/		
	缩框型 Light duty type	50Hz	/	/	/	/	/	/	/	/	/	/	/	/	/	/	/	/	/	/	/	/	/	/	
		60Hz	/	/	/	/	/	/	/	/	/	/	/	/	/	/	/	/	/	/	/	/	/	/	
3700W 5HP	标准型 Standard type	50Hz	/	/	/	32.6	43.6	53.9	64.7	86.3	98.5	107	127	/	/	/	/	/	/	/	/	/	/	/	
		60Hz	/	/	/	29.8	36.0	49.5	58.5	78.4	81.7	97.0	115	/	/	/	/	/	/	/	/	/	/		
	缩框型 Light duty type	50Hz	/	/	/	/	/	/	/	/	/	/	/	/	/	/	/	/	/	/	/	/	/	/	
		60Hz	/	/	/	/	/	/	/	/	/	/	/	/	/	/	/	/	/	/	/	/	/	/	

■高速比输出轴容许扭矩 (3#+6#) High Ratio Output Shaft Torque (3#+6#)

单位Unit: kg-m

功率Power	类型Type	频率Frequency	速比Ratio	扭矩Torque																			
				250	300	350	400	450	500	600	700	800	900	1000	1100	1200	1300	1400	1500	1600	1700	1800	
750W 1HP	标准型 Standard type	50Hz	127	127	127	127	127	127	127	127	127	127	127	127	127	127	127	127	127	127	127	127	127
		60Hz	127	127	127	127	127	127	127	127	127	127	127	127	127	127	127	127	127	127	127	127	127

■高速比 (3#+6#) HIGH RATIO (3#+6#)

