

产品结构图
DETAILS PARTS LIST

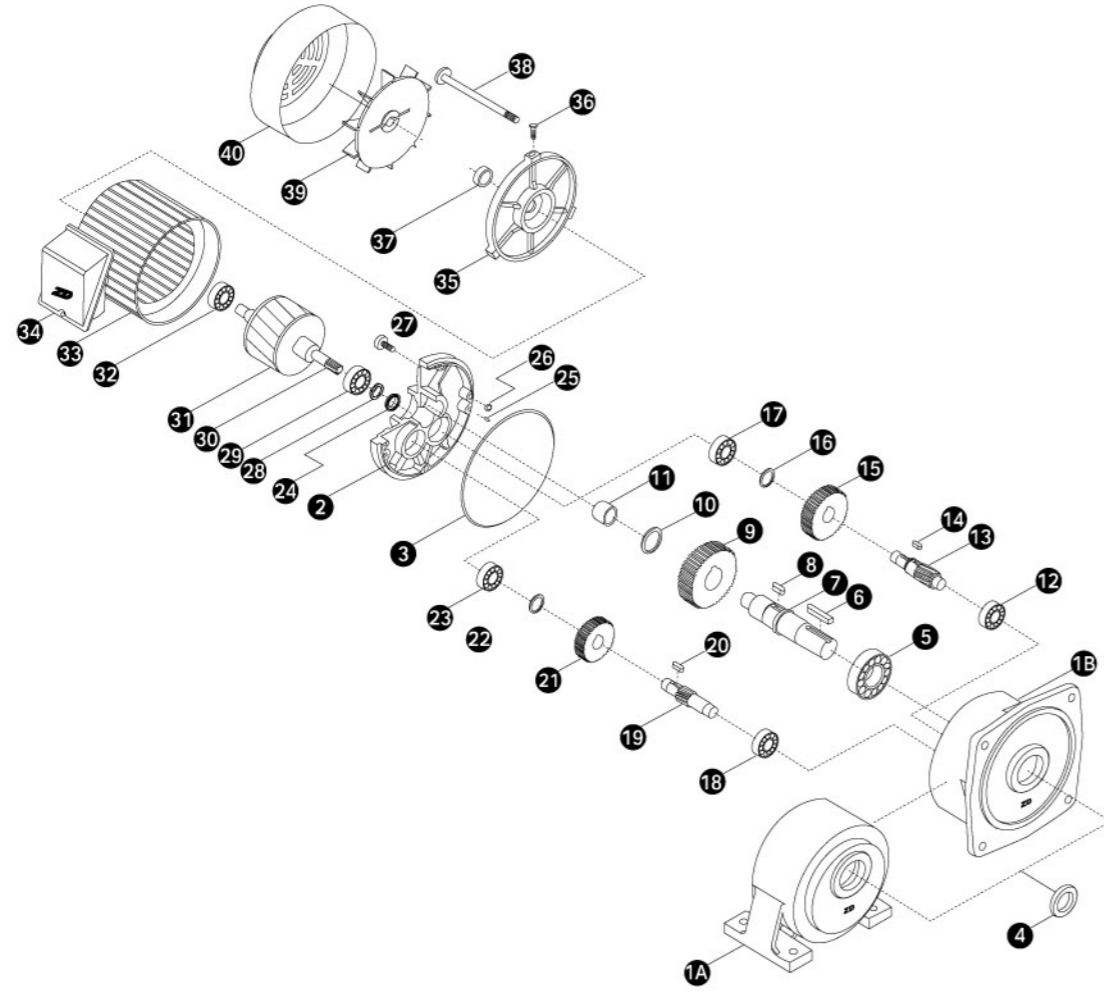

■ 明细表 Parts List

序号 Item	名称Name	序号 Item	名称Name	序号 Item	名称Name
1A	卧式Horizontal Housing	14	三级小齿轴键Key-3RDStage Pinion	28	波形垫圈Wave Spring
1B	立式Vertical Housing	15	二级大齿轮Gear-2ND Stage	29	电机轴承Bearing of Shaft
2	电机前盖Front Cover	16	C-挡圈Snap Ring	30	电机齿轴Motor Shaft
3	O形圈Oil Ring	17	三级齿轴承Bearing-3RDStage Pinion	31	转子Rotor
4	输出轴油封Oil Seal-Output Shaft	18	二级齿轴承Bearing-2NDStage Pinion	32	电机轴承Bearing of Shaft
5	输出轴承Bearing-Output Shaft	19	二级小齿轴Pinion-2NDStage	33	定子总成Stator
6	输出轴键Key-Output Shaft	20	二级小齿轴键Key-2NDStage Pinion	34	铝接线盒Wire Box
7	输出轴Output Shaft	21	一级大齿轮Gear-1ST Stage	35	电机后盖Rear Cover
8	三级小齿轴键Key-3RD Pinion	22	C-挡圈Snap Ring	36	风罩螺钉Screw-Fan Cover
9	三级大齿轮Gear-3RD Stage	23	二级齿轴承Bearing-2NDStage Pinion	37	后盖油封Oil Seal-Rearcover
10	C-挡圈Snap Ring	24	输入侧油封Oil Seal-Motor Shaft	38	电机螺杆Bolt
11	输出轴自润轴承Oilless Bearing	25	定位销Pin	39	风叶Fan
12	二级齿轴承Bearing-2NDStage Pinion	26	O型圈O-Ring	40	风罩Fan Cover
13	三级小齿轴Pinion-3RDStage	27	内六角螺钉Hex-Head Screw		

1#齿轮箱出轴直径 ϕ 18mm配单相电机技术参数
1# GEARBOX WITH SHAFT DIA ϕ 18mm WITH 1-PHASE MOTOR PARAMETERS

■ 卧式 HORIZONTAL

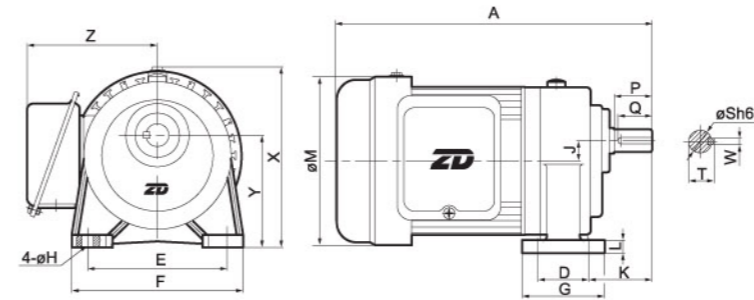

■ 立式 VERTICAL

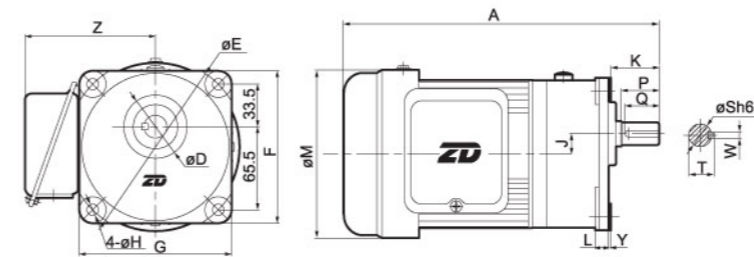

■ 尺寸表 Size Table

单位Unit: mm

	减速比Ratio	A	D	E	F	G	H	J	K	L	M	X	Y	Z	S	P	Q	W	T	重量Weight
100W 1/8HP	标准型3~50	250	40 (50)	110 (140)	135 (120)	65 (120)	9	16	50 (40)	10.5 (12)	133	138 (J)	88.5 (6)	120	18	30	27	5	20.2	5.7
	缩框型60-200	250	40 (50)	110 (140)	135 (120)	65 (120)	9	16	50 (40)	10.5 (12)	133	138 (J)	88.5 (6)	120	18	30	27	5	20.2	5.7
200W 1/4HP	标准型3~10	280	40 (50)	110 (140)	135 (120)	65 (120)	9	16	50 (40)	10.5 (12)	133	138 (J)	88.5 (6)	120	18	30	27	5	20.2	7.0
	缩框型15-90	280	40 (50)	110 (140)	135 (120)	65 (120)	9	16	50 (40)	10.5 (12)	133	138 (J)	88.5 (6)	120	18	30	27	5	20.2	7.0

※表中()内为立式电机尺寸。
※labulation "J" denote Vertical motor dimension.

■ 输出轴容许扭矩Output Torque

单位Unit: kg-m

	标准型 Standard type	缩框型 Light duty type	速比 Ratio																				
			3	5	10	15	20	25	30	40	45	50	60	70	80	90	100	120	140	160	180	200	
100W 1/8HP	50Hz	0.19	0.31	0.62	0.9	1.2	1.4	1.8	2.2	2.7	2.80	/	/	/	/	/	/	/	/	/	/	/	/
	60Hz	0.16	0.26	0.52	0.76	1.00	1.20	1.50	1.90	2.20	2.40	/	/	/	/	/	/	/	/	/	/	/	/
200W 1/4HP	50Hz	0.37	0.62	1.25	/	/	/	/	/	/	/	/	/	/	/	/	/	/	/	/	/	/	/
	60Hz	0.31	0.52	1.04	/	/	/	/	/	/	/	/	/	/	/	/	/	/	/	/	/	/	/
100W 1/8HP	50Hz	/	/	/	/	/	/	/	/	/	/	3.40	3.40	3.40	3.40	3.40	3.40	3.40	3.40	3.40	3.40	3.40	3.40
	60Hz	/	/	/	/	/	/	/	/	/	/	3.40	3.40	3.40	3.40	3.40	3.40	3.40	3.40	3.40	3.40	3.40	3.40
200W 1/4HP	50Hz	/	/	/	1.6	2.1	3.2	3.4	3.4	3.4	3.4	3.4	3.4	3.4	3.4	3.4	3.4	3.4	3.4	3.4	3.4	3.4	3.4
	60Hz	/	/	/	1.3	1.8	2.7	3.2	3.4	3.4	3.4	3.4	3.4	3.4	3.4	3.4	3.4	3.4	3.4	3.4	3.4	3.4	3.4