

POWER OFF ACTIVATED TYPE ELECTROMAGNETIC BRAKE MOTORS 无励磁动作型电磁制动电动机

140W

□ 104mm



规格 / 电动机 SPECS / MOTOR

没有内藏简易制动 This type of motor does not contain a built-in simple brake mechanism.

品名 Model 机型 Type 导线型 Lead Wire Type		额定 Rating	输出功率 Output power W	电压 Voltage V	频率 Frequency Hz	电流 Current A	启动转矩 Starting Torque mN.m	额定转矩 Rated Torque mN.m	额定转速 Rated Speed r/min	电容器容量 Capacitor μ F
齿轮轴型 Pinion Shaft	圆轴型 Round Shaft									
6RK140GU-AM	6RK140A-AM	30min	140	1ph100	50	2.7	700	1080	1250	35.0
					60					
6RK140GU-EM	6RK140A-EM	30min	140	1ph110 1ph120	60	1.80 1.95	700	850	1550	25
6RK140GU-CM	6RK140A-CM	30min	140	1ph220 1ph230	50	1.05 1.15	850	1040	1250	10.0
6RK140GU-HM	6RK140A-HM	30min	140	1ph220 1ph230	60	1.05 1.15	750	850	1550	-
6RK140GU-SM	6RK140A-SM	30min	140	3ph220	50	0.85	2700	1080	1250	-
					60	0.75				

●各种安全规格以电动机铭牌上的型号取得认定。●Ⓢ:内藏热保护装置(自动复位型)。在电机因某种原因过热时会自行启动使电动机停止。●电动机温度下降后恢复运行,故在进行检查作业时请务必事先切断电源。

●When the motor is approved under various safety standards, the model name on the nameplate is the approved model name. ●Contains a built-in thermal protector (automatic return). If a motor overheats for any reason, the thermal protector is opened and the motor stops. ●When the motor temperature drops, the thermal protector closes and the motor restarts. Be sure to turn the motor off before inspecting.

种类 TYPE

●电动机 MOTOR

机型 Type	型号 Model	
	齿轮轴型 Pinion Shaft	圆轴型 Round Shaft
导线型 Lead Wire Type	6RK140GU-AM	6RK140A-AM
	6RK140GU-EM	6RK140A-EM
	6RK140GU-CM	6RK140A-CM
	6RK140GU-HM	6RK140A-HM
	6RK140GU-SM	6RK140A-SM

●平行轴减速器(另售) PARALLEL SHAFT GEARHEAD (SOLD SEPARATELY)

减速器种类 Gearhead Type	减速器型号 Gearhead Model	减速比 Gear Ratio
长寿命·低噪音 Long Life · Low Noise	6GU□K	3、3.6、5、6、7.5、9、12.5、15、18、25、30、36、50、60、75、90、100、120、150、180、200

●减速器型号的□中为减速比的数值

●Enter the gear ratio in the box (□) within the model name

■ 装有减速器时的容许转矩

ALLOWABLE TORQUE WHEN BEING WITH GEARHEAD

- 减速器·中间减速器另售
- 减速器型号的□中为减速比的数值。
- □ 色表示与电动机同一方向运转，其他则为相反方向。
- 转速是以电动机的同步转速 (50Hz: 1500r/min、60Hz: 1800r/min) 为基准除以减速比而算出来的数值。实际转速将随负载大小变化而比所示数值减少 2%~20%左右。
- Gearhead and mid-gearbox can be sold separately.
- Enter the gear ratio in the box (□) within the model name.
- The colored background □ indicates the same rotating direction of the motor while the rotating direction of others are opposite.
- The speed is calculated by dividing the motor's synchronous speed (50Hz: 1500r/min、60Hz: 1800r/min) by the gear ratio. The actual speed is 2%~20% less than the displayed value, depending on the size of the load.

容许力矩单位 Allowance Torque Unit: 上段 Upside (N.m) / 下段 Belowside (kgf.cm)

机型Type 电动机/Gearhead Motor/Gearhead	减速比Gear Ratio	3	3.6	5	6	7.5	9	12.5	15	18	25	30	36	50	60	75	90	100	120	150	180	200			
	转速Speed r/min	50Hz	500	417	300	250	200	166	120	100	83	60	50	41	30	25	20	16	15	12.5	10	8.3	7.5		
6RK140GU-AM 6RK140GU-SM	6GU□K	50Hz	2.6	3.1	4.4	5.2	6.6	7.9	9.9	11.8	14.2	17.8	21.4	25.7	35.6	40	40	40	40	40	40	40	40	40	
6RK140GU-CM			26.5	31.6	44.8	53.0	67.3	80.6	101	120	144	181	218	262	263	400	400	400	400	400	400	400	400	400	
			2.5	3.0	4.2	5.1	6.3	7.6	9.5	11.4	13.7	17.2	20.6	24.7	34.3	40	40	40	40	40	40	40	40	40	40
			25.5	30.6	42.8	52.0	63.2	77.5	96.9	116	139	175	210	252	349	400	400	400	400	400	400	400	400	400	400

容许力矩单位 Allowance Torque Unit: 上段 Upside (N.m) / 下段 Belowside (kgf.cm)

机型Type 电动机/减速器 Motor/Gearhead	减速比Gear Ratio	3	3.6	5	6	7.5	9	12.5	15	18	25	30	36	50	60	75	90	100	120	150	180	200			
	转速Speed r/min	60Hz	600	500	360	300	240	200	144	120	100	72	60	50	36	30	24	20	18	15	12	10	9		
6RK140GU-AM 6RK140GU-HM 6RK140GU-SM 6RK140GU-EM	6GU□K	60Hz	2.1	2.5	3.5	4.2	5.3	6.3	7.9	9.5	11.4	14.4	17.2	20.7	28.7	34.5	40	40	40	40	40	40	40	40	
			21.4	25.5	35.7	42.8	54.0	64.2	80.6	96.9	116	147	175	211	292	352	400	400	400	400	400	400	400	400	400
			2.1	2.5	3.4	4.1	5.2	6.2	7.8	9.3	11.2	14.0	16.8	20.2	28.0	33.7	40	40	40	40	40	40	40	40	40
			21.4	25.5	34.6	41.8	53.0	63.2	79.5	94.8	114	142	171	206	285	343	400	400	400	400	400	400	400	400	400

■ 容许悬挂负载·容许轴向负载

PERMISSIBLE OVERHUNG LOAD AND THRUST LOAD

电动机(圆轴型)→P217
减速器→P217

Motor(Round Shaft)→P217
Gearhead→P217

■ 减速器的容许负载惯性惯量 J

PERMISSIBLE LOAD INERTIA J FOR GEARHEAD

→P218页→P218

■ 起动、制动特性(参考值)

STARTING AND BRAKE CHARACTERISTICS(REFERENCE VALUES)

● 单相电动机 Single-phase Motor

● 三相电动机 Three-phase Motor

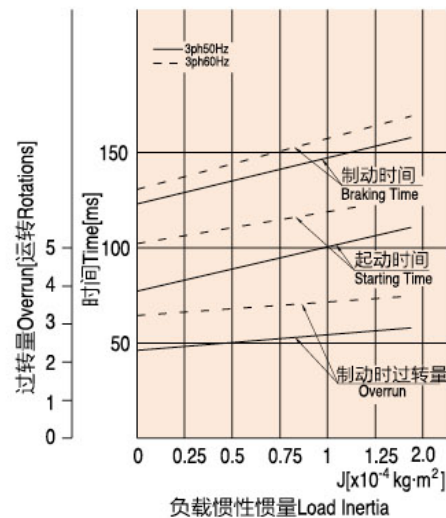
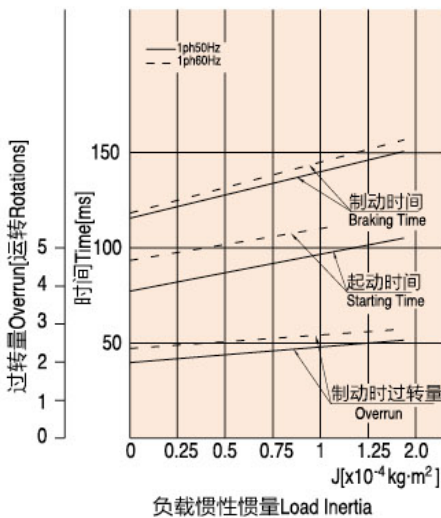

外形图 (单位 mm) DIMENSIONS(Unit mm)

减速器附有安装用螺丝
Mounting screws are included with gearhead.

● 导线型 Lead wiring Type

重量 Weight: 电动机 Motor 5.85kg 减速器 Gearhead 2.1kg

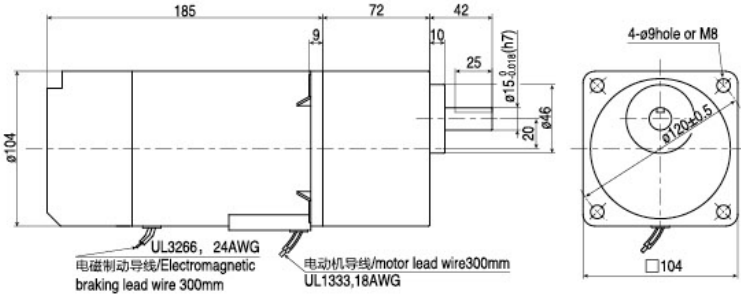

电动机型号 Motor Model	减速器型号 Gearhead Model	减速比 Gear Ratio	L1
6RK140GU-AM 6RK140GU-EM 6RK140GU-CM 6RK140GU-HM 6RK140GU-SM	6GU□K	3~200	72

- 减速器型号的□中为减速比的数值
- Enter the gear ratio in the box (□) within the model name

● 圆轴型的转轴部分 Shaft Section of Round Shaft Type

除重量及轴部外, 电动机外形与齿轮轴相同
Excluding weight and the shaft section Motor shape are the same as those of the pinion shaft

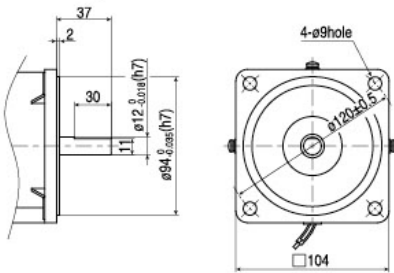

● 键·键槽 (减速器附件)

Key·keywa (The key is included with the gearhead)

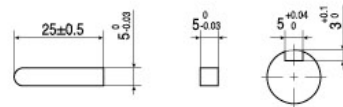

● 电容器外形尺寸 Formal Dimension of Capacitor

型号 Model		电容器型号 Capacitor Model	L	W	H
齿轮轴型 Pinion Shaft	圆轴型 Round Shaft				
6RK140GU-AM	6RK140A-AM	ZD350CFAUL	59	30	42
6RK140GU-EM	6RK140A-EM	ZD250CFAUL	59	30	42
6RK140GU-CM	6RK140A-CM	ZD100BFAUL	58	26	38

- 常规电容器出线为引线, 也可根据客户要求配置插片式187#
- Note: Conventional capacitor is a lead wire type. Inserted 187# is optional

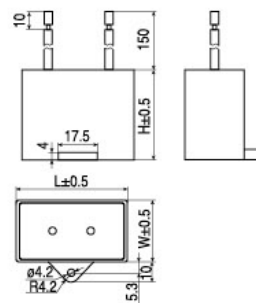

连接图 CONNECTION DIAGRAMS

- 运转方向指从电动机轴看来的方向。CW表示顺时针方向，CCW表示逆时针方向。
- 表中所记品名为齿轮轴型，圆轴型亦同。
- The direction of motor rotation is as viewed from the shaft end of motor.
CW represents the clockwise direction, while CCW represents the counterclockwise direction.
- Name indicated in the list is pinion shaft type, also valid for the equivalent round.

单相电动机 Single-phase Motor

6RK140GU-AM、6RK140GU-EM、6RK140GU-CM、6RK140GU-HM

- SW1为电动机的运行/停止及电磁制动操作开关。(联动) ● SW1设定ON时，电磁制动解除，电动机开始运作。
- SW1设定OFF时，电动机停止，电磁制动开始工作。
- 在电动机停止状态下解除电磁制动时，应将SW1设定为非联动，而仅将色导线侧的接触点设定ON。
- 运转方向 ● 将SW2转换至CW侧时，电动机作顺时针方向运转。 ● 将SW2转换至CCW侧时，电动机作逆时针方向运转。
- SW1 operates both motor and electromagnetic brake action. (Switched Simultaneously)
- The motor will rotate when SW1 is switched simultaneously to ON
- When SW1 is switched simultaneously to OFF, the motor is stopped, set the electromagnetic brake and holds the load.
- If you wish to release the brake while the motor is stopped, set the SW1 to be off and connection point at the side of black lead to be on.
- Direction of Rotation. ● To rotate the motor in a clockwise (CW) direction, turn SW2 to CW. ● To rotate the motor in a counterclockwise (CCW) direction, turn SW2 to CCW.

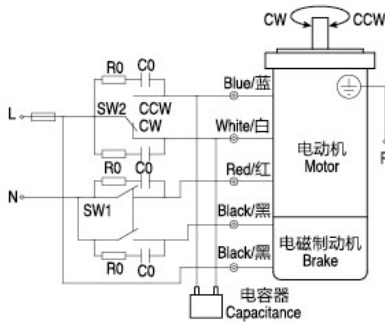

开关号码 Switch NO.	开关的接触点容量Contact capacity switch		参考 Note
	单相100V、110/120V输入 Single-Phase 100VAC, 110/120VAC Input	单相220V、230V输入 Single-Phase 200VAC, 220/230VAC Input	
SW1	AC125V 8A以上 (感应负载) 125 VAC 8A minimum (Inductive Load)	AC250V 8A以上 (感应负载) 250 VAC 8A minimum (Inductive Load)	联动Switched Simultaneously
SW2			

三相电动机 Three-phase Motor

6RK140GU-SM

- SW1为电动机的运行/停止及电磁制动操作开关。(联动) ● SW1设定ON时，电磁制动解除，电动机开始运作。
- SW1设定OFF时，电动机停止，电磁制动开始工作。
- 在电动机停止状态下解除电磁制动时，应将SW1设定为非联动，而仅将色导线侧的接触点设定ON。
- 运转方向 ● 若对换R、S、T中任意二条，电动机逆时针方向运转
- SW1 operates both motor and electromagnetic brake action. (Switched Simultaneously)
- The motor will rotate when SW1 is switched simultaneously to ON
- When SW1 is switched simultaneously to OFF, the moto is stopped, set the electromagnetic brake and holds the load.
- If you wish to release the brake while the motor is stopped, set the SW1 to off and connection point at the side of black lead to be on.
- Direction of Rotation. ● To change the rotation direction, change any two connections among R, S and T.

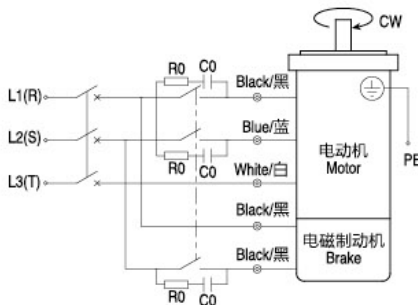

开关号码 Switch NO.	开关的接触点容量Contact capacity switch		参考 Note
	开关的接触点容量Contact capacity switch		
SW1	AC250V 1.5A以上 (感应负载) AC250 VAC 1.5A minimum (Inductive Load)		联动Switched Simultaneously

● 请注意 Note:

- R0C0为吸收电涌电压用CR电路。[R0=5~200Ω C0=0.1~0.2μF、200WV(400WV)]
- 请使用选购配件EPCR1201-2
- R0 and C0 indicate surge suppressor circuit.[R0=5~200Ω C0=0.1~0.2μF, 200WV(400WV)]
- EPCR1201-2 is available as an optional surge suppressor.