

安装 ASSEMBLY

■ 安装马达的步骤 Assembly procedure

客户自行安装伺服马达时，请按以下要领进行安装。伺服马达的尺寸多种多样，除指定的产品外，有些马达可能会无法连接法兰，因为，一定要使用您订货时指定的马达。

If a customer personally assembles the servo motor and reducer please use the following tip. The reducer flange to which the servo motor is attached has different dimensions based on the motor specified. Therefore, assembly may be impossible for some motor. Make sure the correct motor is specified before ordering the reducer.

1、安装无键马达 Spec. in case of assembling a motor without key

- ① 取下橡胶帽，转动输入轴，使螺栓头和橡胶帽的孔吻合。并请确认固定螺栓已松开。
 - ② 将马达轴平稳地插入输出轴（请确保不受阻塞地顺畅的插入）。请充分注意不要让马达倾斜插入。
 - ③ 将马达固定在减速机上，并按指定的扭矩将螺栓拧紧。参考表1
 - ④ 使用扭矩扳手等工具，按指定的扭矩将输入轴的固定螺栓拧紧。参考表2
 - ⑤ 盖上橡胶帽。安装到此结束。
- ① Take off the rubber cap, turn the input shaft, and match the head of the bolt to the hole of the rubber cap. Make sure that the set bolt is loosened.
 - ② Gradually put the motor shaft into the input shaft (Ensure that it is smoothly put in without jam.) Be careful not to be inserted with the motor tilted.
 - ③ Attach the motor to the reducer and fasten the bolt with designated fastening torque. See Table 1.
 - ④ Fasten the set bolt of the input shaft with designated fastening torque using torque wrench, etc. See Table 2.
 - ⑤ Put on a rubber cap. It is the end of assembling.

表1 Table1

马达固定螺栓 Motor combination bolt	拧紧扭矩 Fastening torque	
	N.m	kgf.cm
M3	1.0	10
M4	3.0	30
M5	5.8	60
M6	9.8	100
M8	19.6	200
M10	39.2	400
M12	68.6	700
M16	168	1650

表2 Table2

固定螺栓 Combination bolt	拧紧扭矩 Fastening torque	
	N.m	kgf.cm
M3	1.5	15
M4	3.5	35
M5	7.1	71
M6	12	120
M8	30	300
M10	60	612

带键槽式马达的键取下后，可以像上述无键马达一样安装。无需担心会滑动。
You can assemble the motor with keyway like above when take off the key. There is no risk of dislocation.

■ ZDR系列示意图 ZDR Series Schematic Diagram

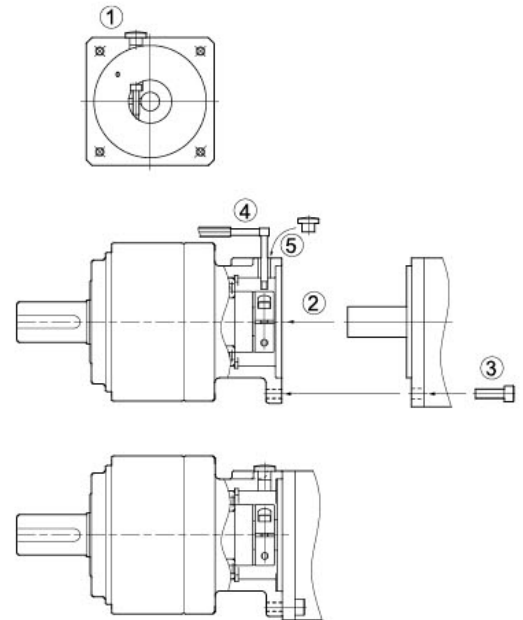

■ ZDE/F/WE/WF/S系列示意图

ZDE/F/WE/WF/S Series Schematic Diagram

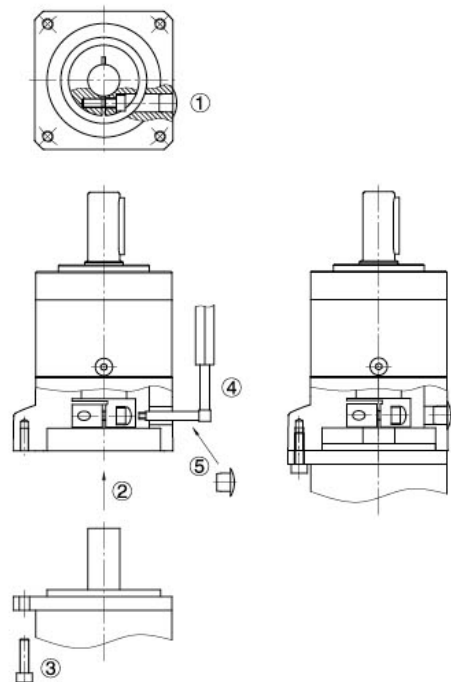

安装 ASSEMBLY

2、安装带键槽马达Spec. in case of assembling a motor with key

- ① 取下橡胶帽，转动输入轴，使螺栓头和橡胶帽的孔吻合。
 - ② 在马达轴上涂上防烧结剂（二氧化钼等），并将键与键槽对上后平稳地插入输出轴（请确保不受阻塞地顺畅的插入）。请务必注意不要让马达倾斜插入。
 - ③ 将马达安装在减速机上，并按指定的扭矩将螺栓拧紧。参考表1
 - ④ 使用扭矩扳手等工具按指定的扭矩将输入轴的固定螺栓拧紧，并确认键已被压紧。参考表3
 - ⑤ 盖上橡胶帽。安装到此结束。
- ① Take off the rubber cap, turn the input shaft, and match the head of the bolt to the hole of the rubber cap.
 - ② Coat carbon formation inhibitors(molybdenum dioxide etc.) onto the motor shaft, match the key to the key slot, and gradually
 - ③ Combine the motor with the reducer and fasten with the designated fastening bolt. See Table 1.
 - ④ For set bolt of the input shaft, fasten using torque wrench with the designated fastening torque with the key firmly pressed. See Table 3.
 - ⑤ Put on a rubber cap. The is the end.



表3 Table3

固定螺栓 Combination bolt	拧紧扭矩Fastening torque	
	N.m	kgf.cm
M4	2.0	20
M5	4.3	43
M6	7.3	73
M8	16.8	168

■ 减速机的安装 Reducer assembly

将减速机安装在设备上时，请在确认安装面平坦且无毛刺等后，使用扭矩扳手等工具按指定的扭矩用螺栓将其固定。参考表4

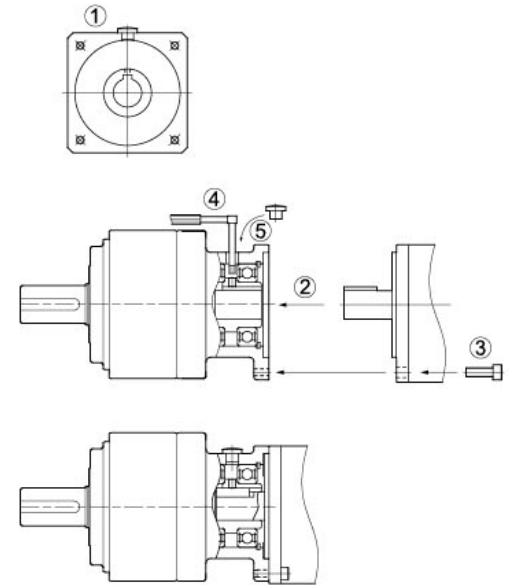
Joining with reducerIn case of joining a reducer with the device, make sure that the combining side is plane without inconsistency, and when assemble reducer outo equipment, ensuring assem- bly surface smooth and without burr. See Table 4.

表4 Table4

减速机固定螺栓Reducercombination bolt	拧紧扭矩Fastening torque	
	N.m	kgf.cm
M5	5.8	60
M6	9.8	100
M8	19.6	200
M10	39.2	400
M12	68.6	700
M16	168	1650

■ 连接输出轴 Connection to the output shaft

注意事项：

- 1、在输出轴上安装耦合器、滑轮等时，请勿在输出轴上施加过大的轴向负荷。
- 2、请勿使用强力将轴敲入，以免使轴承或减速机内部受到损伤。
- 3、安装的耦合器等轴和键槽如有较大松动，可能会导致设备烧毁，安装时请充分注意。
- 4、安装耦合器等时，请使用固定螺栓来将键固定住。
- 5、连接时请充分调校轴心。

Cauti ons

1. When assemble a coupling, pulley, etc. onto the output shaft, make sure that excessive axial load not be given to the output shaft.
2. In case of strongly hitting the shaft with a hammer, the shaft inlet or the inside of the reducer may be damaged, therefore it shall be prohibited.
3. If the shaft or key of a coupling assembled is loosed, it may cause carbonization, so be careful when as-sembling.
4. For assembling of a coupling, fix the key with a set bolt.
5. Please adjust shaft centre carefully in connecting.

